

NOTES:

1. TO INSPECT ASSEMBLY, FOLLOW FIRST ARTICLE AND IN PROCESS INSPECTION SHEET.

2. APPLY LOCTITE 680.

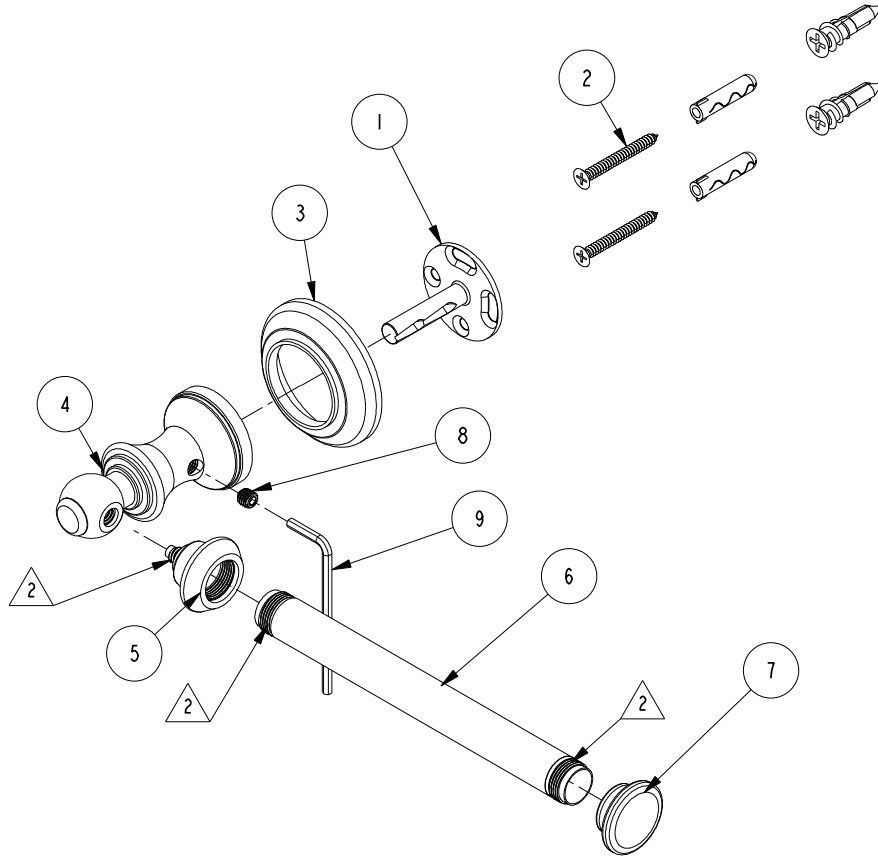

BILL OF MATERIAL (CURRENT LEVEL)

ITEM	PT/ASSY	DESCRIPTION	TYPE	QTY.
1	92914	MOUNTING BRACKET	PART	1
2	1-206	HARDWARE PACK	ASSEMBLY	1
3	2-656	HANDLE ESCUTCHEON ASM	ASSEMBLY	1
4	40853	TISSUE HOLDER POST	PART	1
5	40740	FINIAL, SINGLE TISSUE HOLDER	PART	1
6	40741	TUBE, TISSUE HOLDER	PART	1
7	40742	FINIAL	PART	1
8	92031	SCRW, M6 X 1 X 6 SKT HD CUP PT W/ SELF LOC SS	PART	1
9	10615	HEX KEY, 3MM ALLOY STEEL	PART	1

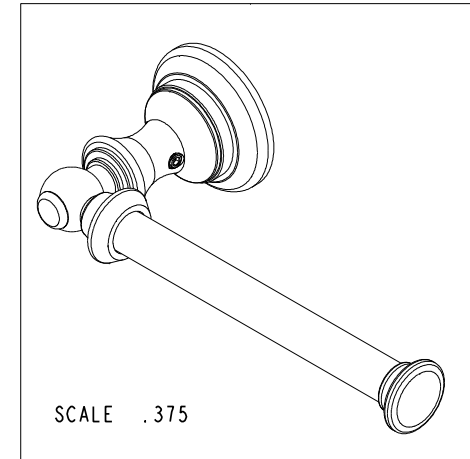

ZONE	REV	DESCRIPTION	DATE	APPROVED
-	B	EN-4263	01/27/21	J.M.
-	A	EN-3950	09/03/19	J.M.
-	-	EN-1266	06/02/10	J.M.

COPYRIGHT 2005 BRASSTECH, INC. THESE DRAWINGS AND THE DESIGNS DEPICTED HEREIN ARE THE PROPRIETARY PROPERTY OF BRASSTECH. ANY USE OR REPRODUCTION IS SUBJECT TO THE EXPRESS APPROVAL OF BRASSTECH. UNAUTHORIZED USE IS STRICTLY PROHIBITED. ALL RIGHTS RESERVED.

TESTING	-	-	-
ASSEMBLY	-	-	-
PLATING	-	-	-
POLISHING	-	NEXT ASSY	USED ON
MACHINING	-	APPLICATION	
TOOLING FIXTURE #	REMOVE ALL BURRS AND SHARP EDGES		

UNITS ARE: INCHES [MM]		
TOLERANCES ARE:		
FRACTIONS	DECIMALS	ANGLES
±1/16"	.X ±.1 [2.5]	±1°
	.XX ±.06 [1.5]	
(X.XXX) DENOTES CRITICAL DIMS. ALL THREADS ARE CRITICAL		
DRAWN	R.S.	06/21/19
CHECKED	J.M.	06/21/19
APPROVED	J.M.	06/21/19

<b>BRASSTECH</b>		2001 CARNEGIE AVE. SANTA ANA, CA 92705 (949) 417-5207	
INCORPORATED			
TOILET TISSUE HOLDER			
DWG NO.		REV	
35-27		B	
SCALE	REF.	SHEET	OF
.375	-	1	2

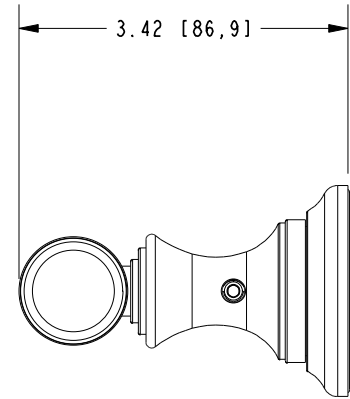
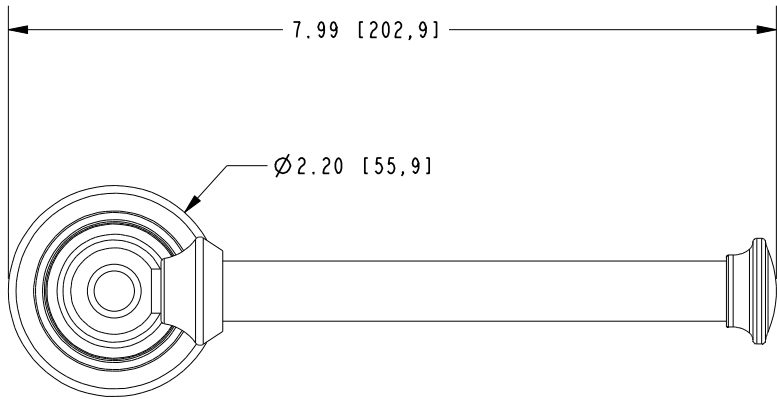
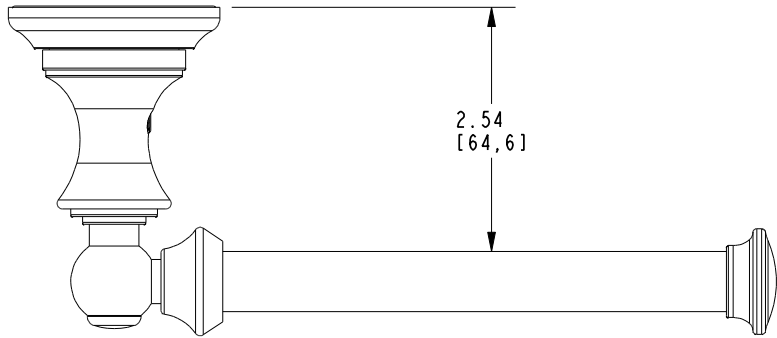

**BRASSTECH**

2001 CARNEGIE AVE.  
SANTA ANA, CA 92705  
(949) 417-5207

INCORPORATED

DWG NO.

35-27

REV

B

SCALE .111

REF. -

SHEET 2 OF 2